

Description	Material	Finish
Body	Brass	Nickel
Socket	Be Cu	Gold
Insulation	PTFE	N/A

REVISIONS			
REV	DESCRIPTION	DATE	APPV
B	Updated footprint and dimensions; Added new title block	29-JUN-12	SAH
C	Added socket to PCB dimension	17-OCT-12	SAH

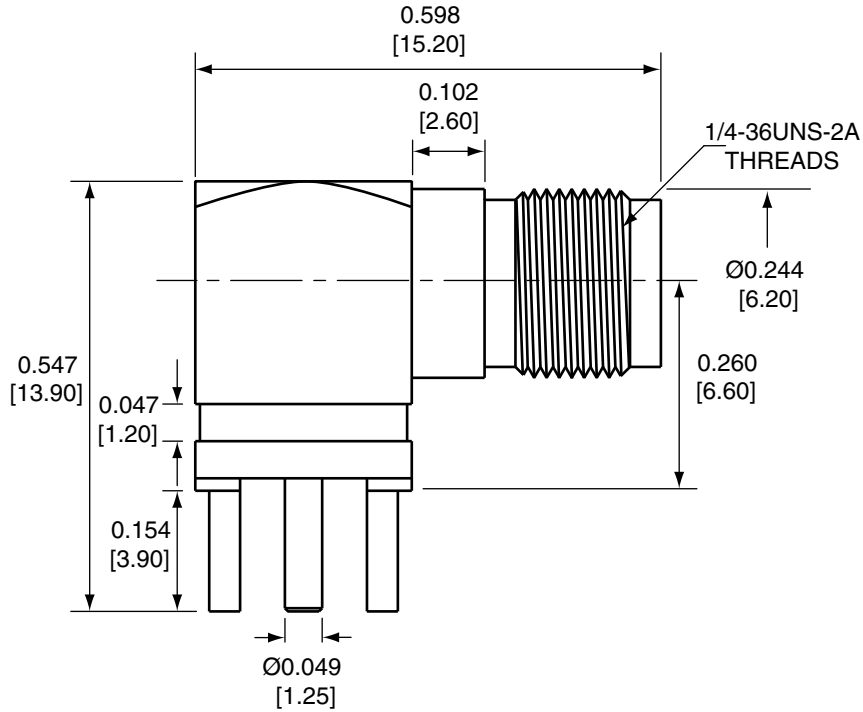

SIDE VIEW

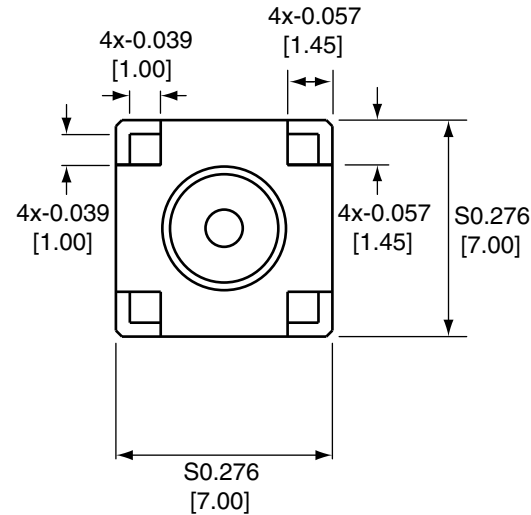

BOTTOM VIEW

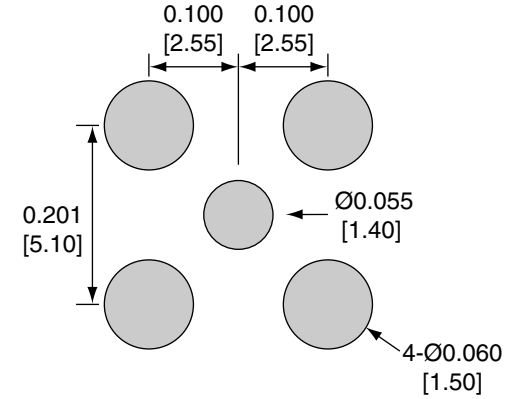

RECOMMENDED FOOTPRINT

NOTES: (UNLESS OTHERWISE SPECIFIED)

1. ALL DIMENSIONS ARE IN INCHES [mm].
2. DIMENSIONS APPLY AFTER FINISHING.
3. MANUFACTURE TO BE COMPLIANT WITH EU RoHS DIRECTIVE.
4. SAFETY BREAK ALL SHARP CORNERS AND EDGES .02 MAXIMUM.

WARNING: THIS DRAWING CONTAINS PROPRIETARY INFORMATION THAT IS THE SOLE PROPERTY OF LINX TECHNOLOGIES, AND SHALL BE TREATED AS SUCH. NO DISCLOSURE OR REPRODUCTION OF THIS DOCUMENT IS PERMITTED, IN WHOLE OR IN PART, WITHOUT THE EXPRESS WRITTEN PERMISSION OF LINX TECHNOLOGIES OR ITS DESIGNATED AGENTS.

MATERIAL:	TOLERANCES: .020 [0.50]-1.200 [30.00]= ±.008 [0.20] .200 [5.00]-1.200 [30.00]= ±.016 [0.40] 1.20 [30.0]-4.75 [120.0]= ±.024 [0.60] 4.75 [120.0]-12.40 [315.0]= ±.040 [1.0]	PROJECTION: 
FINISH:	DRAWN: B.MURPHY	DT: 29-JUN-12
	ENGR: S.HOGAN	DT: 29-JUN-12

Linix		159 ORT LANE MERLIN, OR 97532	
TITLE: SMA FEMALE RIGHT ANGLE PCB MOUNT			
SIZE A	DWG. NO. CON SMA002	REV C	
SCALE: 2:1	DO NOT SCALE DRAWING	SHEET 1 OF 1	