

**SINGLE-PHASE GLASS PASSIVATED
SILICON BRIDGE RECTIFIER**

VOLTAGE RANGE 50 to 1200 Volts CURRENT 1.5 Ampere

FEATURES

- * Surge overload rating - 60 amperes peak
- * Ideal for printed circuit board
- * Reliable low cost construction utilizing molded
- * Glass passivated device
- * Polarity symbols molded on body
- * Mounting position: Any

MECHANICAL DATA

- * Epoxy : Device has UL flammability classification 94V-0
- * UL listed the recognized component directory, file #E94233



DB-S

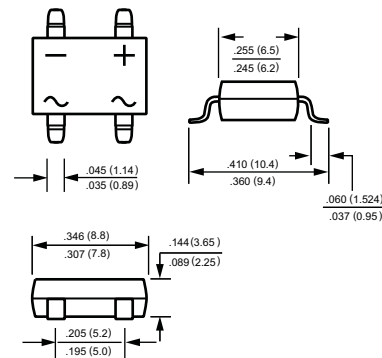

MAXIMUM RATINGS AND ELECTRICAL CHARACTERISTICS

Ratings at 25 °C ambient temperature unless otherwise specified.
Single phase, half wave, 60 Hz, resistive or inductive load.
For capacitive load, derate current by 20%.

MAXIMUM RATINGS (At TA = 25°C unless otherwise noted)

RATINGS	SYMBOL	DB151S	DB152S	DB153S	DB154S	DB155S	DB156S	DB157S	DB1512S	UNITS
Maximum Recurrent Peak Reverse Voltage	V _{RRM}	50	100	200	400	600	800	1000	1200	Volts
Maximum RMS Bridge Input Voltage	V _{RMS}	35	70	140	280	420	560	700	840	Volts
Maximum DC Blocking Voltage	V _{DC}	50	100	200	400	600	800	1000	1200	Volts
Maximum Average Forward Output Current at TA = 40°C	I _o	1.5								Amps
Peak Forward Surge Current 8.3 ms single half sine-wave superimposed on rated load (JEDEC method)	I _{FSM}	60								Amps
Typical Current Squared Time	i ² T	14.9								A ² S
Typical thermal resistance	R _{θJA}	40								°C/W
	R _{θJC}	30								
	R _{θJL}	15								
Operating and Storage Temperature Range	T _J , T _{STG}	-55 to + 150								°C

ELECTRICAL CHARACTERISTICS (At TA = 25°C unless otherwise noted)

CHARACTERISTICS	SYMBOL	DB151S	DB152S	DB153S	DB154S	DB155S	DB156S	DB157S	DB1512S	UNITS
Maximum Forward Voltage Drop per Bridge Element at 1.5A DC	V _F	1.0								Volts
Maximum Reverse Current at rated DC Blocking Voltage per element	@TA = 25°C	1.0								uAmps
	@TA = 125°C	0.05								mAmps

NOTE: Suffix "-s" Surface Mount for Dip Bridge.

2022-09/97
REV:E

RATING AND CHARACTERISTIC CURVES (DB151S THRU DB1512S)

FIG. 1 - MAXIMUM NON-REPETITIVE FORWARD SURGE CURRENT

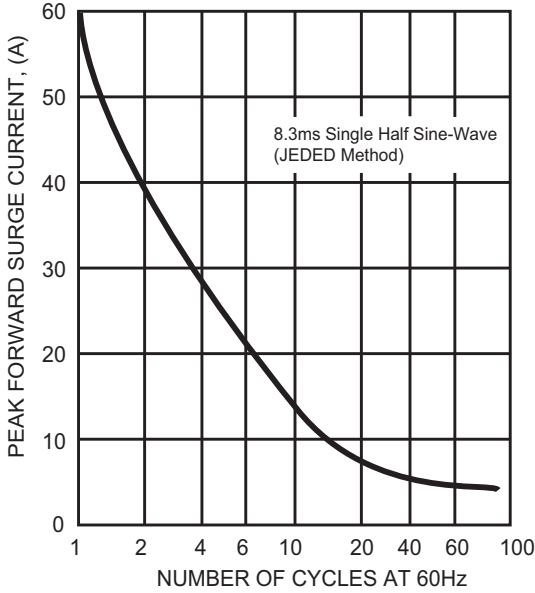

FIG. 2 - TYPICAL FORWARD CURRENT DERATING CURVE

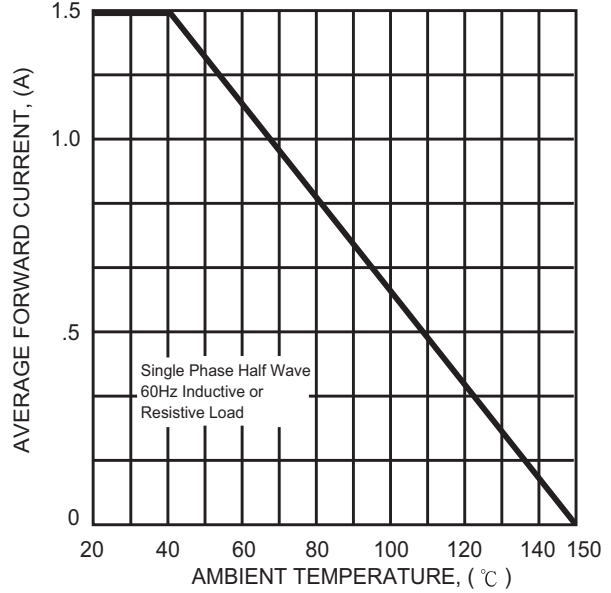

FIG. 3 - MAXIMUM INSTANTANEOUS FORWARD CHARACTERISTICS

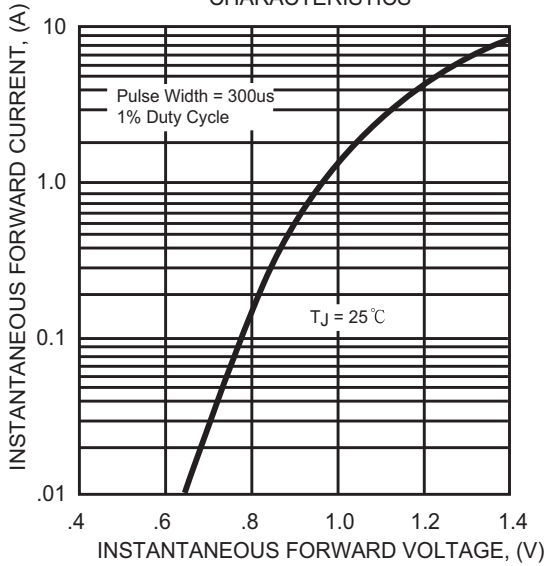
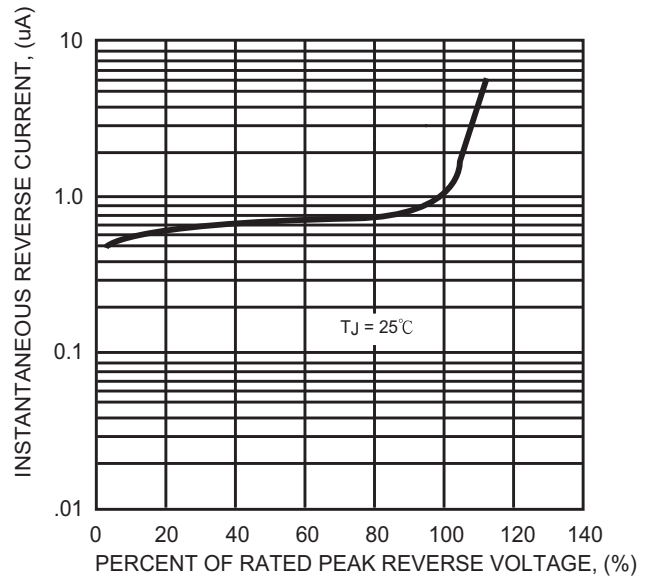
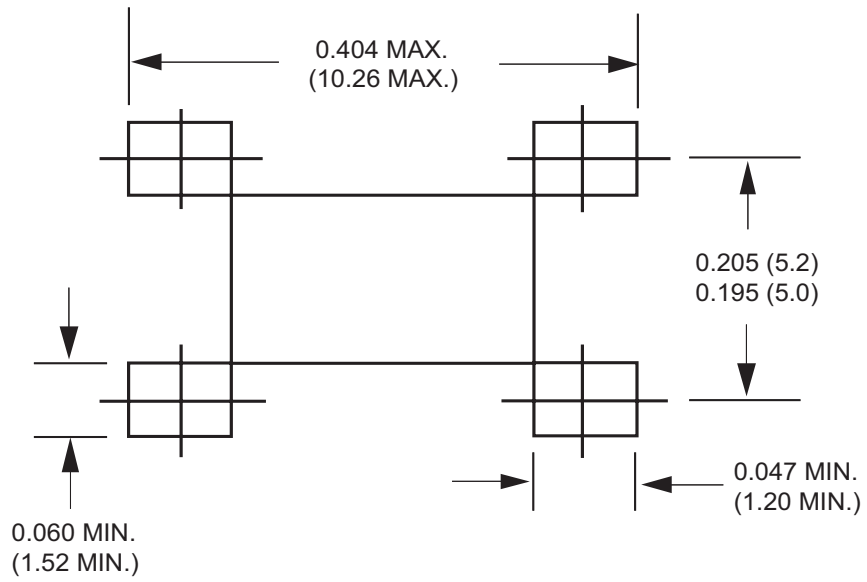

FIG. 4 - MAXIMUM REVERSE CHARACTERISTICS



Mounting Pad Layout



Dimensions in inches and (millimeters)



RECTRON

Attachment information about DB15XS

1. Internal Circuit

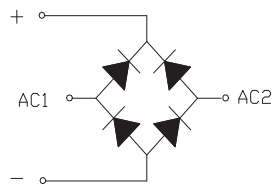

2. Marking on the body

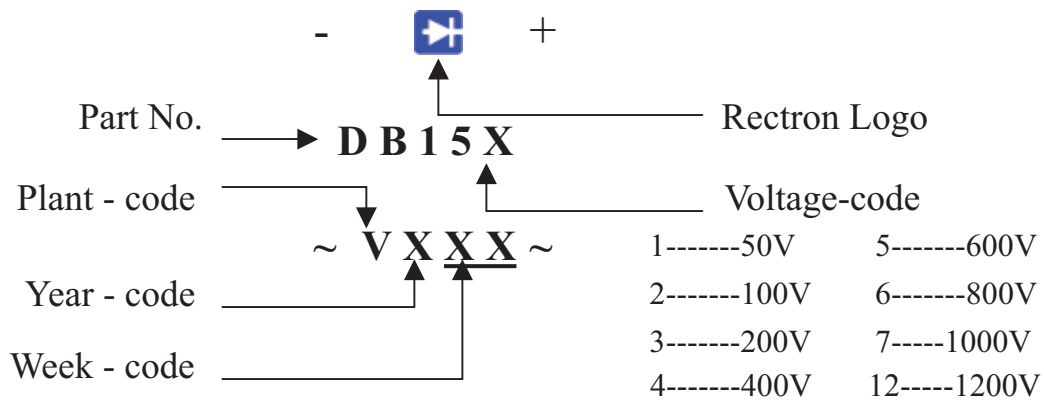



RECTRON

Attachment information about DB15XS

3. Items marked on the inner box and carton

3.1 On the box (for -C)

CUSTOMER
TYPE
LOT NO.
QUANTITY
Q.A.
DATE

3.2 On the reel

CUSTOMER
TYPE
QUANTITY
LOT NO.
Q.A.
REMARK

3.3 On the carton

CUSTOMER
TYPE
QUANTITY
LOT NO.
REMARK

PACKAGING OF DIODE AND BRIDGE RECTIFIERS

REEL PACK

PACKAGE	PACKING CODE	EA PER REEL	EA PER INNER BOX	COMPONENT SPACE (mm)	TAPE SPACE (mm)	REEL DIA (mm)	CARTON SIZE (mm)	EA PER CARTON	GROSS WEIGHT(Kg)
DB-S	-T/W	1,000	1,000	9.5	52	330	360*355*360	8,000	9.8



DISCLAIMER NOTICE

Rectron Inc reserves the right to make changes without notice to any product specification herein, to make corrections, modifications, enhancements or other changes. Rectron Inc or anyone on its behalf assumes no responsibility or liability for any errors or inaccuracies. Data sheet specifications and its information contained are intended to provide a product description only. "Typical" parameters which may be included on RECTRON data sheets and/ or specifications can and do vary in different applications and actual performance may vary over time. Rectron Inc does not assume any liability arising out of the application or use of any product or circuit.

Rectron products are not designed, intended or authorized for use in medical, life-saving implant or other applications intended for life-sustaining or other related applications where a failure or malfunction of component or circuitry may directly or indirectly cause injury or threaten a life without expressed written approval of Rectron Inc. Customers using or selling Rectron components for use in such applications do so at their own risk and shall agree to fully indemnify Rectron Inc and its subsidiaries harmless against all claims, damages and expenditures.

