

DESCRIPTION	MATERIAL	FINISH
BODY	BRASS	GOLD
SOCKET	BeCu	GOLD
INSULATION	PTFE	N/A

REVISIONS			
REV	DESCRIPTION	DATE	APPV
A	INITIAL RELEASE OF LINX INTERNAL DRAWING	11-JUN-13	SAH

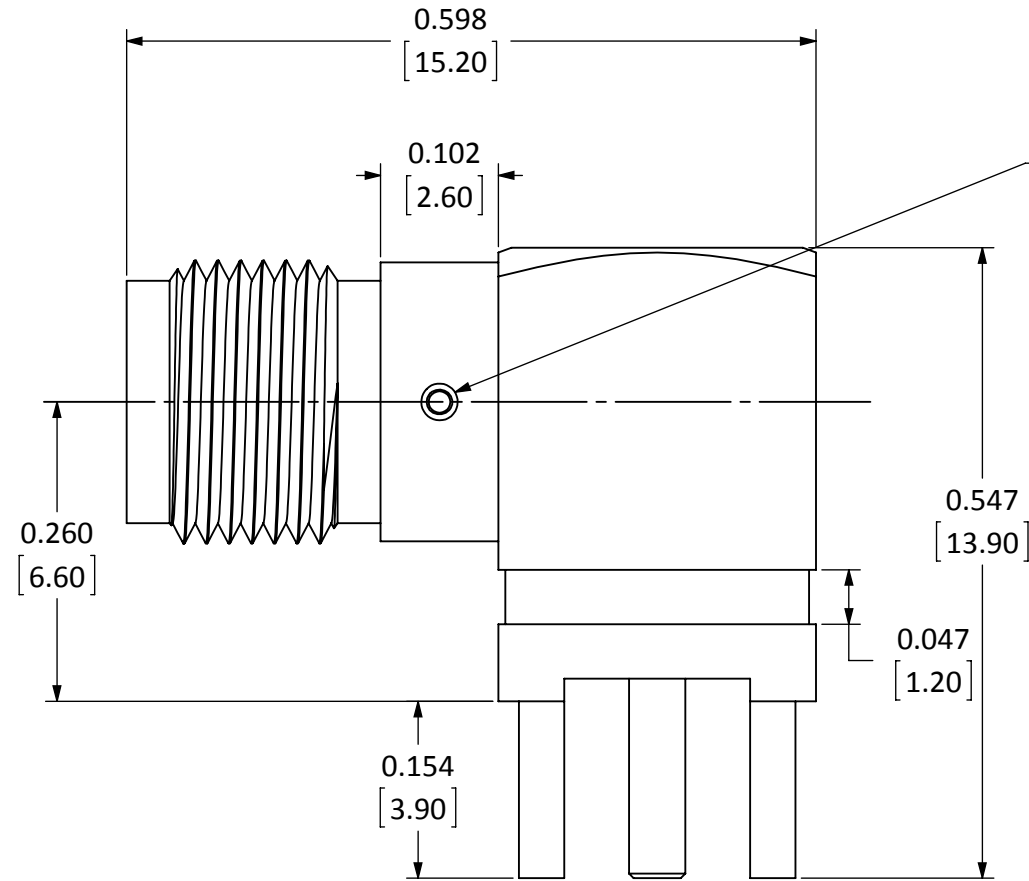

SIDE VIEW

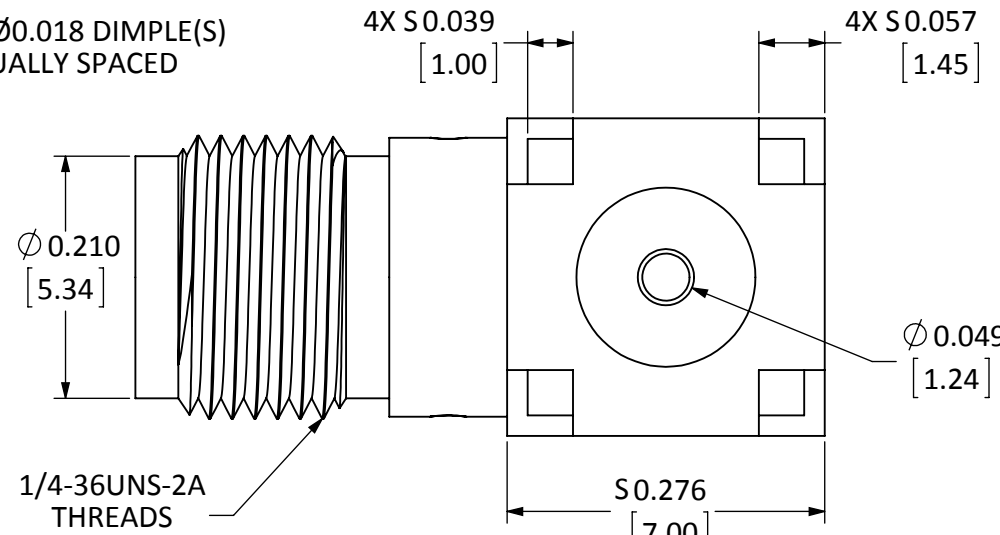

BOTTOM VIEW

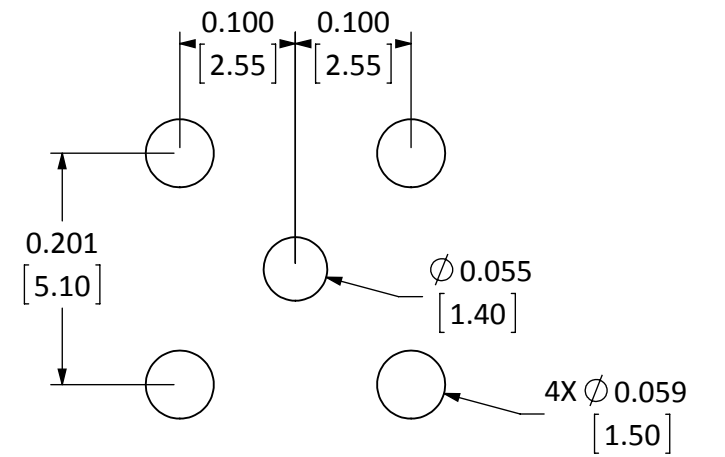

RECOMMENDED FOOTPRINT

- NOTES: (UNLESS OTHERWISE SPECIFIED)
1. ALL DIMENSIONS ARE IN INCHES [mm].
 2. DIMENSIONS APPLY AFTER FINISHING.
 3. MANUFACTURE TO BE COMPLIANT WITH EU RoHS DIRECTIVE.
 4. SAFETY BREAK ALL SHARP CORNERS AND EDGES .02 MAXIMUM.

WARNING: THIS DRAWING CONTAINS PROPRIETARY INFORMATION THAT IS THE SOLE PROPERTY OF LINX TECHNOLOGIES, AND SHALL BE TREATED AS SUCH. NO DISCLOSURE OR REPRODUCTION OF THIS DOCUMENT IS PERMITTED, IN WHOLE OR IN PART, WITHOUT THE EXPRESS WRITTEN PERMISSION OF LINX TECHNOLOGIES OR ITS DESIGNATED AGENTS.

MATERIAL:	INTERPRET DIMENSIONS AND TOLERANCES PER ASME Y14.5.	PROJECTION:
FINISH:	SURFACE FINISH: $\sqrt{}$ ANGLES: $\pm 1^\circ$	
	TOLERANCES: .X $\pm .1$.XX $\pm .01$.XXX $\pm .005$	
	DRAWN: B.MURPHY DT: 3-APR-13	
	ENGR: S.HOGAN DT: 11-JUN-13	



TITLE: SMA FEMALE RIGHT ANGLE PCB MOUNT

SIZE	DWG. NO.	REV
B	CON SMA002-G	A
SCALE: 6:1	DO NOT SCALE DRAWING	SHEET 1 OF 1